



Yamaha '99-'05 YZF-R6 Installation Instructions (Slip on system)

Thank you for selecting and purchasing a TiForce exhaust system for your Yamaha R6. TiForce is the world's finest titanium exhaust system available today. To reduce installation time, please read and review these instructions before beginning the installation process. Instructions are also available in Adobe Acrobat PDF format on the TiForce website (www.TiForce.co.jp).

Before Installation

- Verify that all parts and accessories have been included (see list below).
 - Coat all exhaust pipe mating joints with anti-seize compound / lubricant.
 - Read and review these instructions, cautions, diagrams and images prior to starting any work.
-
1. Remove the fairing lowers.
 2. Disconnect the stock S-bend from the rear of the collector and set aside. Save the stock exhaust clamp for reuse (new clamp provided). Save the stock end can mounting bolt for reuse as well.
 3. Install the TiForce S-bend to the rear of the stock head pipes and collector. Make sure the system fits flush and snug. Reuse the stock exhaust clamp or the provided clamp and loosely attach for now.
 4. Install the TiForce end can to the S-bend tail pipe.
 5. Loosely attach the two rubber bands, stainless steel bands (K), and stay to the end can using the supplied 6mm hardware (H) and the hanger / stay arm (G). (See figure 1).
 6. Place the bands approximately 195mm from the edge of the end can. (See figure 2).
 7. Carefully align the two stainless bands so that they are parallel to each other, and spaced properly on the can. Tighten the 6mm hardware (H). Make sure that the rubber pads fully cover the bands (K). **USE CAUTION WHEN TIGHTENING THE 6MM HARDWARE AND THE TWO BANDS SO AS NOT TO CRUSH OR DISTORT THE SLEEVE OF THE CAN.**
 8. Using some brake and contact cleaner on a clean rag, carefully wipe down the entire exhaust system to remove any residual oils, anti seize, fingerprints and dirt prior to starting the motor. **FAILURE TO CLEAN THE TUBING AND CAN MAY RESULT IN PERMANENT STAINING OF THE SYSTEM WHEN HEATED.**
 9. Attach the supplied springs to secure the end can to the S-bend pipe. Make sure the exhaust system is free and clear of the bike. If necessary, adjust for proper clearance.
 10. Go back and tighten all fasteners.
 11. Check that all fasteners are tightened per specifications, then start the motor and check for exhaust leaks.
 12. Reinstall the fairing lowers.

End.



General Cautions For Exhaust System Installations

CAUTION –For your safety, carefully read these instructions and those above, and fully familiarize yourself with the content before beginning installation and use. Keep these instructions in a safe place for future reference. Install the exhaust system as explained in these instructions.

DANGER –when the motor is running, and shortly after it has been turned off, the motorcycle, the exhaust system and end-can will be hot. Severe burns, bodily injury and even death may result.

DANGER –Keep gasoline and other flammable materials away from the exhaust system at all times. Exposure of gasoline and to heat can lead to fire.

CAUTION –Stop the motorcycle should the exhaust system come in contact with people or animals. Never touch the exhaust system when hot. Direct contact with the system can cause burns.

DANGER –Allow the motor to cool before installing or removing the exhaust system. Working with a hot motor can lead to burns.

CAUTION –Stand the motorcycle on a flat and level surface and ensure that the motorcycle is stable before installing the exhaust system. Bodily injury and /or death could result to you or others if the motorcycle falls over. Damage may also result to the motorcycle or nearby property or equipment.

DANGER –Start and run the motorcycle in a well-ventilated area. With prolonged exposure to exhaust gas you run the risk of severe oxygen deficiencies, bodily injury or death may result.

CAUTION –Install the muffler only on the specified model of motorcycle. Improper installation will lead to loss of performance and or damage to the motorcycle.

CAUTION –Do not disassemble, modify or remodel this exhaust system.

TiForce Japan Co., Ltd.
13-25, Minami Ejima
Suzuka city, Mie
510-0235, Japan

81-593-873992 tel
81-593-873993 fax

<http://tiforce.co.jp>
sales@tiforce.co.jp

Enclosed parts

Exhaust S-bend pipe	1	Exhaust spring	2
End can	1	Stainless steel bands K	2
Short stay arm / hanger G	1	Rubber pad	2
M6 x 20mm allen bolt H	2	Exhaust Clamp	1
M6 nut	2		
M6 washer	4		

Figure 1 - Assembly of Stainless Bands and Exhaust Hanger

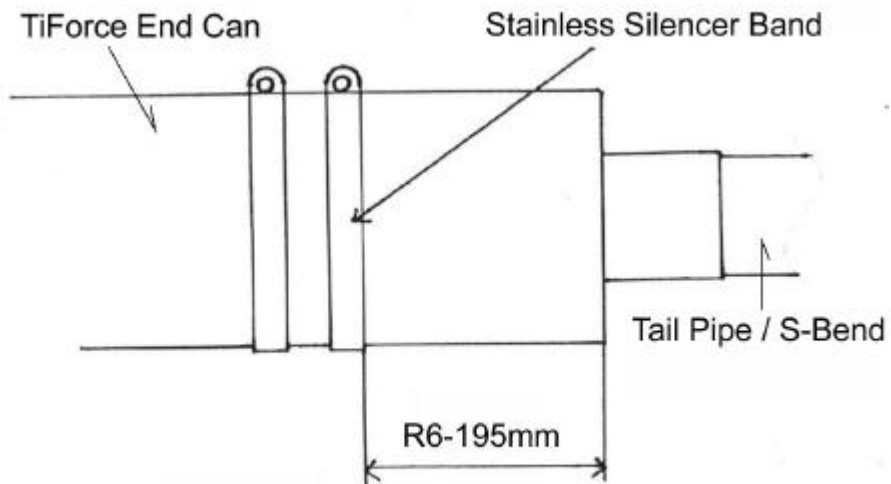
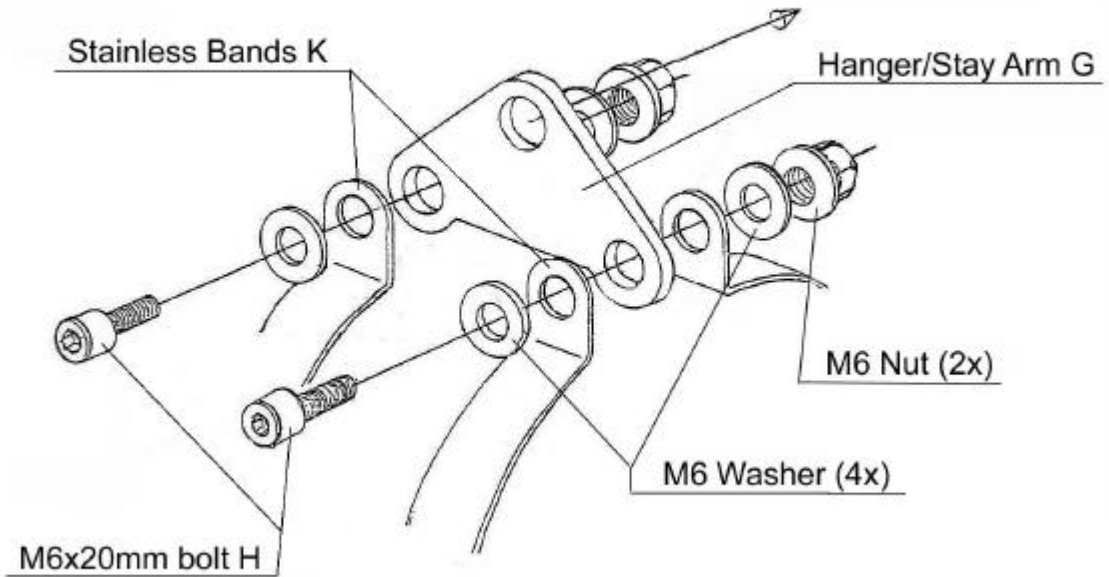

Figure 2 - R6 Silencer Band Placement