

Adjustable foot peg kit for Kawasaki ZX-10R Users Manual

Thank you for purchasing Ti-Force original parts. Please read the information below for safe use of our product.

! Caution !

To prevent burns, work must be conducted only after the engine has properly cooled down.
 To ensure the bike does not fall over as you work on it, make sure it is stood on level ground.
 During the installation of the kit make sure that all parts are securely tightened to prevent from falling plate or loose master-cylinder. Pay special attention to the brake system, errors can cause serious injury.
 After installation, make sure that the parts of the kit are not touching other parts.
Some parts are loosely tightened at the time of shipment. Please make sure all parts are securely tightened during the installation.
 Vibration can loosen the bolts while riding. Please regularly check all parts are securely tightened.
 Especially after any fall accident, please make a thorough check.
 This product is for standard motorbikes and those with our exhaust installed. There is possibility that this product can not be installed when the motor bike has another non-standard exhaust, swing arm or frame, etc.
 Do not dismantle or alter our product. (It causes loss of function, and could cause fatal accidents.)
 Please note we can not accept return of a kit when it has been illegally used or installed.
 If the motorbike has had a fall and its frame has been damaged, the installation of the kit may not be possible.
In case of accident and damage to our product, please do not use. The broken parts may cause harm to the rider.
The accident might cause the exhaust to fall off the motorbike and thus fatal accident or injury.

- 【Spec】** 《Suitable motor bike》 06- ZX-10R
 《Position》 Nine positions available (Ref 1)
 《Other info》 Shift Stroke of three levels adjustment (Ref 2)
 *For 20mmUP, STD and High shift only (A-high, B-Standard, C-low)
 Standard fitment or in the reverse position.
 *Require to cut the faring in the reserve position.
 Passenger foot pegs can be used.

- 【Required Tools etc.】**
 《Tools》 Hexagon wrench 4mm, 5mm, 6mm, one of each
 Spanner 12mm, 13mm one of each
 Spanner 10mm, two of each
 Torque wrench, Radial punch, Spring puller
 《Others required》 Gloves, Screw stop paste, grease, Cloth

【Tightening Torque】
 Recommended Tightening Torque

Screw diameter	N·m	Kg f·m
M6 Bolt, Nut	10	1.0
M8 Bolt, Nut	22	2.2

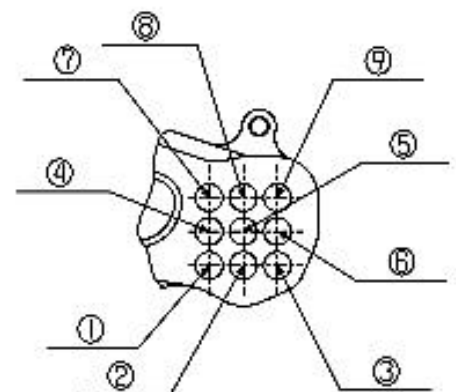

《Fig 1》 Change-side position

1 Position confirmation
 Confirm the position.

0mm Back/ 0mmU P	10mm Back/ 0mmU P	20mm Back/ 0mmU P
0mm Back/10mmU P	10mm Back/10mmU P	20mm Back/10mmU P
0mm Back/20mmU P	10mm Back/20mmU P	20mm Back/20mmU P

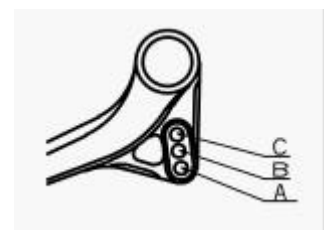

《Fig 2》 Shift arm position

If you choose setting or position as in Fig 1, the shift rod can be installed only at A or B as in Fig 2.
 * recommend to choose position B (STD).

- 2 Remove STD foot peg from the motor bike body.
Remove the brake master ASSY and brake switch from the brake-side STD step.
For the shift-side, engine-side change arm only requires the STD, therefore remove the link arm from the STD link.

- 3 Attach the right-side step plate to the motor bike body.

- (1) Cut the heat cover like Photos 1 to prevent from interfering the brake light switch and the heat cover.

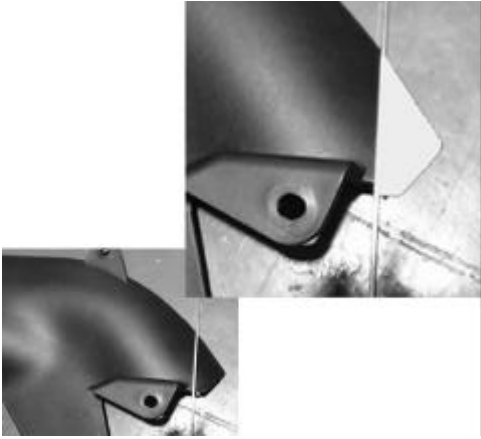

- (2) Remove the flange 6 angle bolt (No.29) and button screw (No.25) that is supporting the master cylinder stay.
After applying the screw lock paste to the bolt, attach it to the place of your choice with the flange angle bolt (No.29) and button screw (No.25).

- (2) Change the STD parts for the foot peg to the one you use.

- Master cylinder
- Stop switch

Note: In position and , find the best position of the Banjo not to interfering the heat cover and brake hose.

- (3) Adjust the brake light switch. (Check the brake light comes on when you press the pedal.)

Note: If you are unable to adjust with the switch screw, change the angle of the switch stay and/or the brake arm side spring stay.

If you make adjustment to the switch stay, check that no parts interfere with other parts.

- (4) Check no part touches the other parts.

- Check all bolts and nuts are securely tightened.
- It is essential you check the hose bent between the R master and fluid reservoir, as well as the brake hose mechanism, when the swing arm goes up and down.

- 4 Attach the left-side foot peg plate to the motor bike body

- (1) Change the chain slider attachment bolt to the supplied bolt (No.42) and washer (No.43).

- (2) Attach the peg to the body.

- (3) Adjust the length of the change rod and position of the pedal.

Make sure the screws have more than 6mm engagement at all three change rods.

- (4) Check no parts interfere with others.

- (5) Check all bolts and nuts are securely tightened.

- 5 Adjustment of change rod

If the spherical bearing is too short or long, and you can not make to your required heights, change the angle of the change arm and adjust the length of the change rod.

- In case of reverse position, change the direction of change arm.



6 Confirmation

(1) Check before run

- No parts interfere other parts.
(Especially moving parts.)
- All moving parts work smoothly.
- All bolts and nuts are securely tightened.
- If the rear brake works.
- If the brake light operates.

(2) Check after the run

- If the shift to each gear can be done smoothly.
- If all bolts and nuts are still securely tightened.

【About maintenance】

Please keep the bearing and spherical bearing parts oiled at all times to ensure smooth operation. The bolts and nuts can be loosened by vibration. Please regularly tighten them. Especially after a fall, check the bolts and nuts.

【Parts list】

Utmost care is provided to the quality for the product. In case of ambiguity, stop using it immediately and contact us. Please contact below for inquiry on installation and maintenance, or claims.

No.	item name	qty.
1	LEFT SIDE STEP PLATE	1
2	RIGHT SIDE STEP PLATE	1
3	MASTER CYLINDER STAY	1
4	HEEL GUARD (L)	1
5	HEEL GUARD (R)	1
6	STEP BAR (R)	1
7	STEP BAR (L)	1
8	BRAKE PEDAL	1
9	CHANGE PEDAL PLATE	1
10	PEDAL END	2
11	FLUSH BOLT M6 X 25	2
12	PEDAL INNER COLLAR SUS1415	1
13	PEDAL END RUBBER	2
14	SHIFT ROD 180MM	1
15	SHIFT ROD 60MM	1
16	SWTICH STAY- A	1
17	SWITCH STAY-B	1
18	PUSH ROD ADJUST NUT	1
19	PUSH ROD PIN	1
20	ALUMINUM COLLAR 24X8X6	2
21	ALUMINUM COLLAR 24X8X5	2
22	BUTTON BOLT M6X10	4
23	BUTTON BOLT M6X12	1
24	BUTTON BOLT M6X15	1
25	BOTTON BOLT M6X20	1
26	U NUT M6R	2
27	CAP BOLT M6X25	1
28	CAP BOLT M8X25	4
29	HEXAGON FLANGED BOLT M8X50	1
30	HEXAGON FLANGED BOLT M8X65	1
31	FLUSH BOLT M8X25	1
32	FLUSH BOLT M8X35	1
33	BUTTON BOLT M8X25	1
34	WASHER M6	1
35	WASHER M8X22X1.6	2
36	U NUT M8	2
37	U NUT M6R	1
38	NUT M6	1
39	NUT M6L	1
40	SPILIT PIN 2X20	1
41	SPHERICAL BEARING	1
42	SPECIAL BOLT M6X20	1

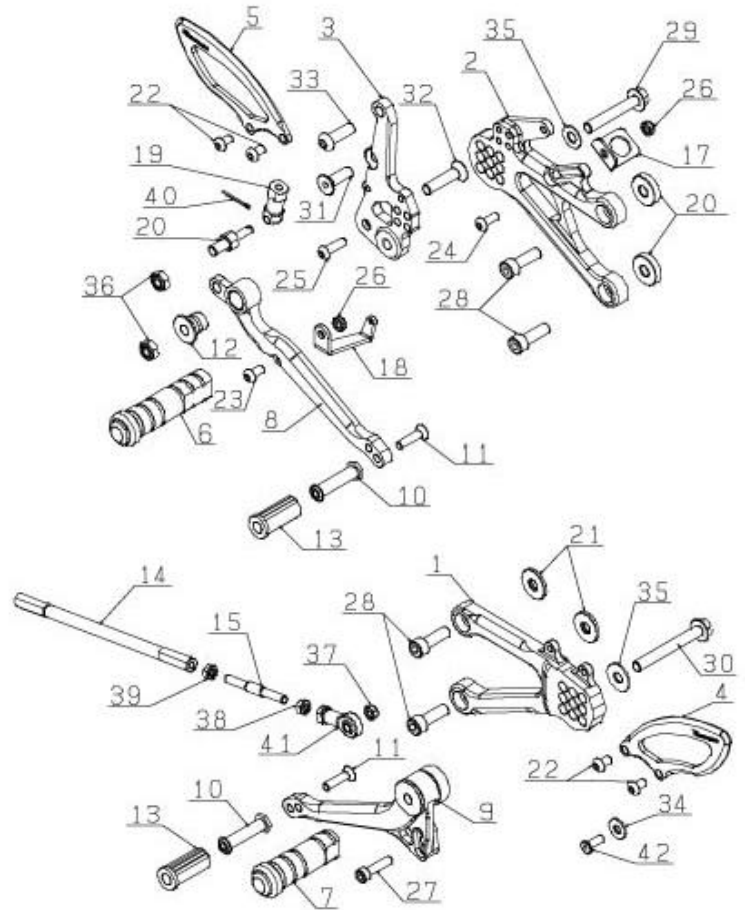

TiForce Japan Co., Ltd.
8160-1, Kou-cho,
Suzuka city, Mie
513-0836, Japan

81-593701881 tel
81-593701882 fax

<http://tiforce.co.jp>
sales@tiforce.co.jp